

HSE Global Scholarship Competition - 2021

DEMO VERSION OF COMPETITION ASSIGNMENTS  
PHYSICS  
11<sup>th</sup> GRADE

to be completed within 120 minutes  
the maximum score is 100 points

**Assignment 1**

A coastal lighthouse keeper observes the sea from a height of 15m. Given that the Earth's radius is much larger than the height of the lighthouse, and the medium of light propagation is isotropic, how will the maximum range of vision change if the keeper's observation point is positioned 45m higher?

**Answer:** it will increase 2x (15 points)

**Assignment 2**

A typical reaction describing the bombardment of uranium nuclei with slow neutrons is as follows:

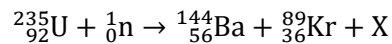

- 1) Which product is hidden behind X?
- 2) Calculate the energy yield from reaction Q, provided that the mass of the uranium isotope is equal to 235.044 unified amu, the neutron isotope - 1.009 unified amu, the barium isotope - 143.923 unified amu, and the krypton isotope - 88.918 unified amu. The coefficient of correlation between mass and energy is  $931.5 \text{ MeV} \cdot \text{amu}^{-1}$

**Answer:**  $3^1_0\text{n}$ ,  $172,328 \text{ MeV}$  (20 points)

**Assignment 3**

A spacecraft, moving at a speed of  $0.78c$ , receives a signal from an orbital station about an approaching unidentified object. The station's sensors were triggered by the dangerous approach speed of the two objects ( $0.94c$ ) and have established that the length of the unidentified object is 80m.

- 1) What is the speed of the unidentified object in relation to the station?
- 2) What is the proper length of the unidentified object?

Please note that the orbital station is *stationary*.

**Answer:**  $V_1 \approx 0,6c$ ,  $L_0 \approx 100\text{m}$  (20 points)

#### Assignment 4

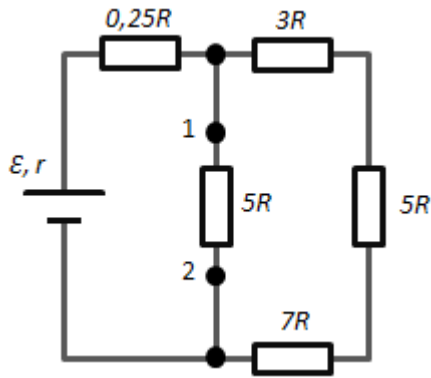

Five resistors with known electrical resistance are connected as a circuit diagram (as shown in the figure). A current source with  $EMF=\mathcal{E}$  is connected to the ends of this circuit; the source resistance value is unknown. The current value in the circuit between points 1 and 2 is  $3I$ .

Please identify the short-circuit current.

**Answer:**  $I_{s-c} = \frac{4\mathcal{E}I}{\mathcal{E}-16IR}$  (20 points)

#### Assignment 5

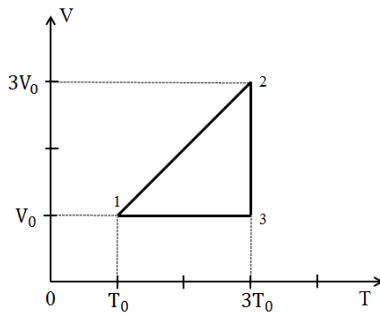

One mole of an ideal monatomic gas is involved in a cyclic process, as shown in the figure:

- 1) Draw this cycle in P-V coordinates;
- 2) Calculate the thermal efficiency of the cycle.

**Answer:**  $\eta = 0.2$  (25 points)